

ThunderBolt®Pro-XTM



ICCONS
Serious Connections®

Includes AS 5216:2021 Compliant Range

TDS | 1027.3

FREE DOWNLOAD
www.iccons.com.au



**DESIGN
PRO**
ADVANCED ANCHOR DESIGN SOFTWARE



Hex Zinc Clear



Hex Galvanised



Hex Stainless Steel



CSK Stainless Steel

THUNDERBOLT®PRO-XTM



National
Code
Compliant



European
Technical
Assessment



Cracked
Concrete
Approved



Fire
Rated
Fasteners





ThunderBolt® Pro-XTM Concrete Screw Anchor

The ICCONS ThunderBolt® Pro-XTM is a high performance dual hardness concrete screw anchor that also comprises of a select range complying with AS 5216:2021. It's now available in zinc plated carbon steel and mechanically galvanized carbon steel to complement the stainless steel grade 316 range. The two-step heat treatment process provides greater ductility and ensures effective quick installation in all base material strengths. The ThunderBolt® Pro-XTM is designed for high load, close to edge applications in both indoor and outdoor environments. The unique cutting action of the ThunderBolt® Pro-XTM provides stress free installation in concrete and masonry materials.

ThunderBolt® Pro-XTM Concrete Screw Anchor

- Dual Hardness technology for use in hard concrete
- Mechanically galvanized - Ideal for outdoor environments
- Available in flanged hex head
- Fast installation at reduced torque
- Stamped Hex Head for fast and accurate anchor identification
- Flanged hex head locking serrations designed to resist loosening and improve dynamic load performance
- Chamfered tip centres anchor and aids installation
- Designed for cracked and non-cracked concrete
- No expansion, ideal for close to edge applications
- Removeable
- Fire rated range
- ETA assessment
- Complies with AS 5216:2021 (Design of post-installed and cast-in fastenings in concrete)*

*Refer to select range

ThunderBolt® Pro-XTM eliminates hydrogen embrittlement issues

Hydrogen embrittlement corrosion occurs through diffusion of hydrogen into the metal as well as corrosion due to the application environment, brittleness in the metal creates weakness and cracks within the structure of the metal. Also known as Hydrogen assisted corrosion cracking, it fosters an environment in which the product can fail in an unpredictable manner, potentially creating a "safety critical" issue. This issue is controlled in the manufacturing process of the ThunderBolt® Pro-XTM removing this potential problem..

Carbon Steel and Bi-Metal concrete screw anchor dimensions

Anchor Size		5	6	8	10	12	16
Major diameter	mm	6.4	7.5	10	12.5	14.3	18.6
Core diameter	mm	4.5	5.5	7.4	9.4	11.3	15.3
Thread pitch	mm	4.5	4.5	5.8	7.8	8.1	10.9

Material content

	Bi-metal screw anchor	Screw anchor
Steel grade	Austenitic (316)	Carbon steel
Steel specification	A4 (1.4401) EN10263-5	10B21 (SAE-J403)
Tensile strength (min)	500N / mm ²	850N / mm ²
Material of hardened tip	Steel according to EN10263-4	10B21 (SAE-J403)
Coating	N/A	Zinc Electroplated (≥5µm)
		Mechanically Galvanised (45µm)



ThunderBolt®Pro-XTM HEX HEAD Zinc Clear and Galvanised Specifications

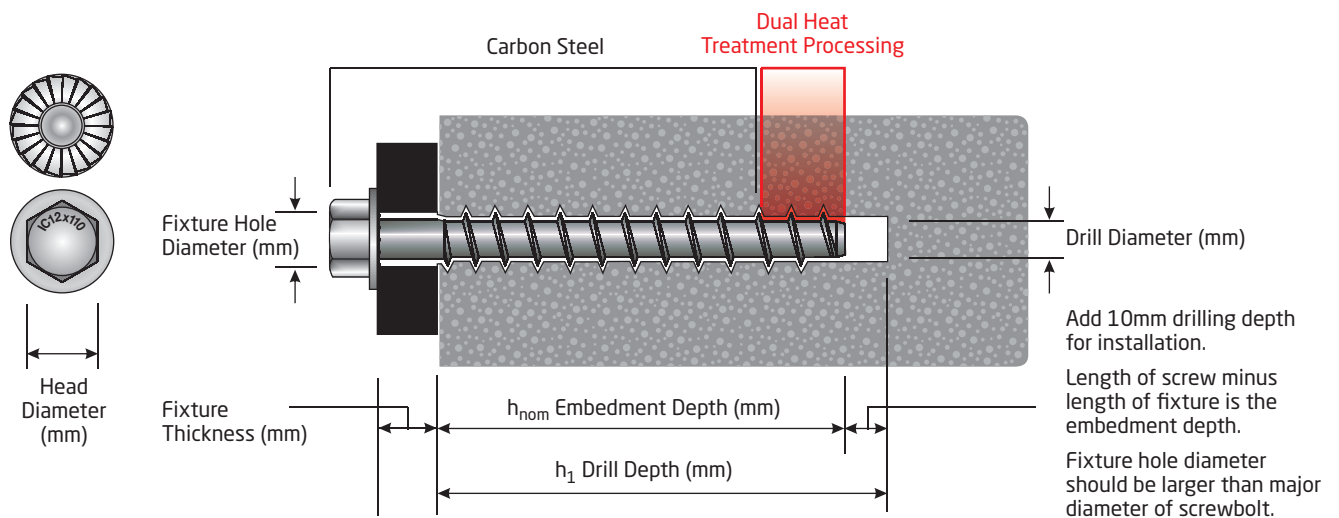

ThunderBolt®Pro-XTM Hex Head Stainless Steel Specifications

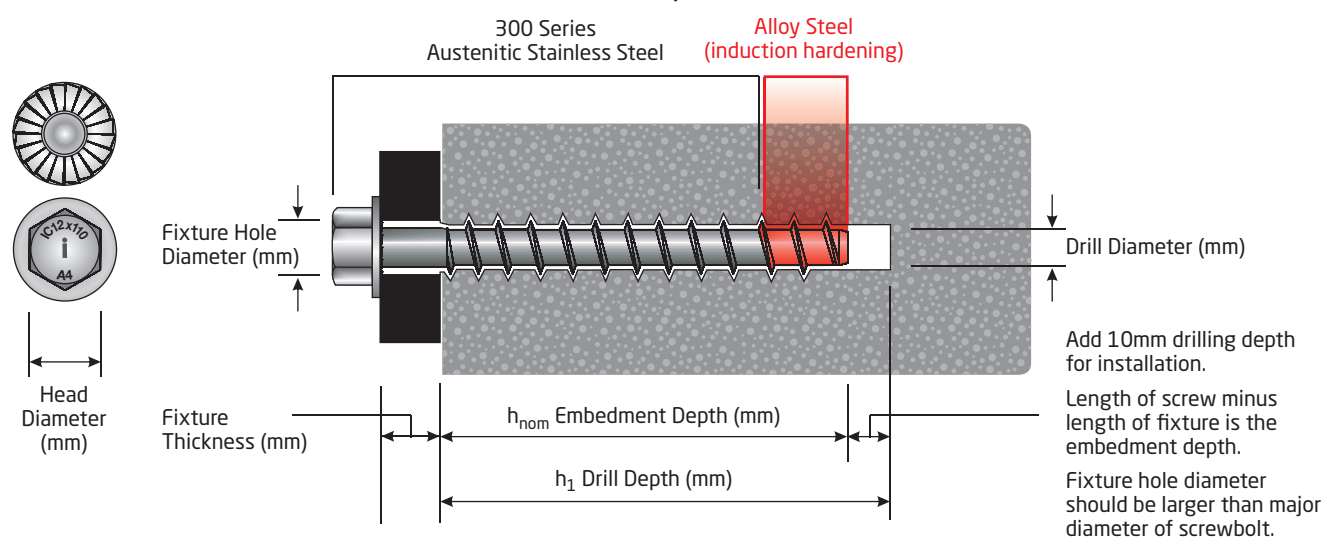

ThunderBolt®Pro-XTM Countersunk Stainless Steel Specifications

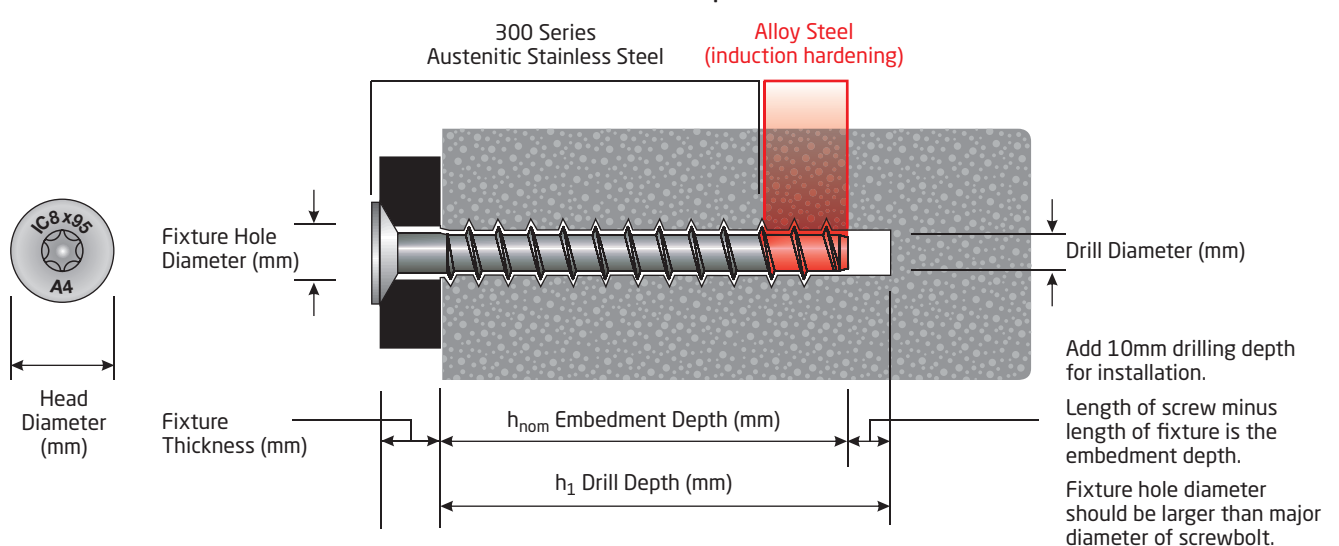

ZINC CLEAR

INCLUDES AS 5216:2021 COMPLIANT RANGE

Flanged hex head with locking serrations designed to resist loosening and improve dynamic load performance

Asymmetric thread profile provides unparalleled bite in concrete

15 degree thread design provides fast installation and optimum performance

Stamped head for fast and accurate anchor identification

Diameter
ICCONS ID
Length

ThunderBolt®Pro-XTM (Zinc Clear)

ZINC INTERNAL



Part No.	Head Style	Description (mm)	Drill Size (mm)	Embedment Depth h _{nom} (mm)	Drill Depth h ₁ (mm)	Fixture Thickness (mm)	Clearance Hole (mm)	T _{inst} (Nm)	Impact Screw Gun T _{max} (Nm)	Installation Socket (mm)	ETA Assessment	Qty Inner	Qty Outer
Approved range - ETA-RNSS (multiple fixings) ETA-18/0644													
SXTM06060-A	Hex	6 X 60	6	55	65	5	9	20	80	10	ETA-RNSS	100	600
SXTM06075-A	Hex	6 X 75	6	55	65	20	9	20	80	10	ETA-RNSS	100	600
SXTM06100-A	Hex	6 X 100	6	55	65	45	9	20	80	10	ETA-RNSS	100	600
AS 5216:2021 Compliant Range - ETA-Option 1 (single fixings) ETA-18/0643													
SXTM08075-A	Hex	8 X 75	8	65	75	10	11	40	185	13	ETA 1	100	500
SXTM08100-A	Hex	8 X 100	8	65	75	35	11	40	185	13	ETA 1	100	400
SXTM10100-A	Hex	10 X 100	10	75	85	25	13	60	350	17	ETA 1	50	250
SXTM10120-A	Hex	10 X 120	10	75	85	45	13	60	350	17	ETA 1	50	250
SXTM10140-A	Hex	10 X 140	10	75	85	65	13	60	350	17	ETA 1	50	250
SXTM12100-A	Hex	12 X 100	12	95	105	5	15	80	350	19	ETA 1	50	150
SXTM12120-A	Hex	12 X 120	12	95	105	25	15	80	350	19	ETA 1	25	125
SXTM12150-A	Hex	12 X 150	12	95	105	55	15	80	350	19	ETA 1	25	75
Range not included in ETA Assessment													
SXTM05050	Hex	5 X 50	5	25	35	25	7	15	80	8	-	100	1600
SXTM06030	Hex	6 X 30	6	25	35	5	9	20	80	10	-	100	1600
SXTM06050	Hex	6 X 50	6	30	40	20	9	20	80	10	-	100	1200
SXTM08050	Hex	8 X 50	8	40	50	10	11	40	185	13	-	100	600
SXTM08060	Hex	8 X 60	8	40	50	20	11	40	185	13	-	100	600
SXTM10060	Hex	10 X 60	10	50	60	10	13	60	350	17	-	50	250
SXTM10075	Hex	10 X 75	10	50	60	25	13	60	350	17	-	50	250
SXTM12075	Hex	12 X 75	12	60	70	15	15	80	350	19	-	50	150
SXTM16100	Hex	16 X 100	16	80	90	20	19	100	350	24	-	15	60
SXTM16150	Hex	16 X 150	16	80	90	70	19	100	350	24	-	15	60

* Max. power output of impact screw gun | ETA-RNSS = ETA Redundant Non Structural System | ETA 1 = ETA Option 1 = AS 5216 Compliant

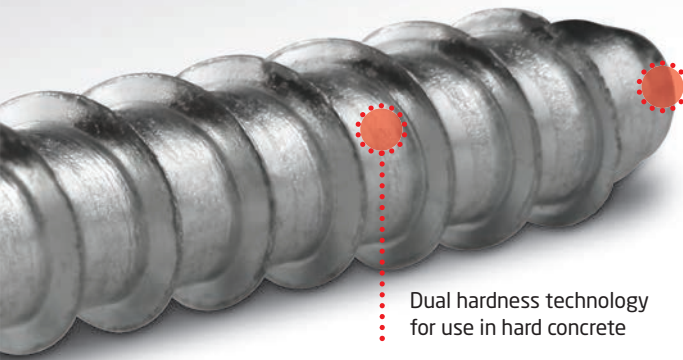

Chamfered tip centres anchor and aids for easy installation

Unique two step heat treatment process

1st Step Case hardening to provide the shank of the screw with adequate strength, good ductility and hydrogen embrittlement resistant characteristics.

2nd Step Selective through hardening to provide the drill point and lead threads with good drilling and tapping performance.

Dual hardness technology for use in hard concrete

Lower-hardness (below 34 HRC) load bearing section

Higher hardness 55 HRC (min) drill point and lead threads for reliable under-cutting of the base material



National Code Compliant



European Technical Assessment



Cracked Concrete Approved



Fire Rated Fasteners



Free Download iccons.com.au

Design Loads - approved ThunderBolt®Pro-XTM - Hex Head (Zinc Clear)

Part No.	Size (mm)	Embed. Depth h_{nom} (mm)	Non cracked concrete						Cracked concrete						$C_{cr,N}$ (mm)	$S_{cr,N}$ (mm)	C_{min} (mm)	S_{min} (mm)
			20 MPa		32 MPa		40 MPa		20 MPa		32 MPa		40 MPa					
			Tension (kN)	Shear (kN)	Tension (kN)	Shear (kN)	Tension (kN)	Shear (kN)	Tension (kN)	Shear (kN)	Tension (kN)	Shear (kN)	Tension (kN)	Shear (kN)				
Design Loads - ETA-RNSS (multiple fixings) ETA-18/0644 (Part 6)																		
SXTM06060-A	6	55	3.3	5.3	4.2	5.3	4.7	5.3	3.3	5.3	4.2	5.3	4.7	5.3	64	128	40	40
SXTM06075-A	6	55	3.3	5.3	4.2	5.3	4.7	5.3	3.3	5.3	4.2	5.3	4.7	5.3	64	128	40	40
SXTM06100-A	6	55	3.3	5.3	4.2	5.3	4.7	5.3	3.3	5.3	4.2	5.3	4.7	5.3	64	128	40	40
Design loads - ETA Option 1 (single fixings) ETA-18/0643 - AS 5216:2021 Compliant Range																		
SXTM08075-A	8	65	4.3	11.3	5.4	11.3	6.0	11.3	2.1	8.3	2.7	10.5	3.0	11.3	76	152	50	50
SXTM08100-A	8	65	4.3	11.3	5.4	11.3	6.0	11.3	2.1	8.3	2.7	10.5	3.0	11.3	76	152	50	50
SXTM10100-A	10	75	10.7	14.5	13.4	17.9	15.0	17.9	6.7	10.2	8.4	12.9	9.4	14.4	88	175	60	60
SXTM10120-A	10	75	10.7	14.5	13.4	17.9	15.0	17.9	6.7	10.2	8.4	12.9	9.4	14.4	88	175	60	60
SXTM10140-A	10	75	10.7	14.5	13.4	17.9	15.0	17.9	6.7	10.2	8.4	12.9	9.4	14.4	88	175	60	60
SXTM12100-A	12	95	13.9	26.0	17.5	26.0	19.6	26.0	6.7	26.0	8.4	26.0	9.4	26.0	114	226	70	70
SXTM12120-A	12	95	13.9	26.0	17.5	26.0	19.6	26.0	6.7	26.0	8.4	26.0	9.4	26.0	114	226	70	70
SXTM12150-A	12	95	13.9	26.0	17.5	26.0	19.6	26.0	6.7	26.0	8.4	26.0	9.4	26.0	114	226	70	70

Note: The ThunderBolt® Pro-XTM anchor may be used in cracked or non-cracked concrete applications subject to static or quasi-static loading in reinforced or unreinforced normal weight concrete of strength classes C20/25 - C50/60. • Performance data in the above table has been calculated using the relevant published ETA documents and based on single anchor installation at characteristic spacing and edge distance parameters. • Compliance is in accordance with AS 5216:2021, for specific design calculations refer to ICCONS Designfix software for further details.

• $C_{cr,N}$ = Characteristic edge distance, $S_{cr,N}$ = Characteristic spacing, C_{min} = Minimum edge distance, S_{min} = Minimum spacing

Recommended Loads - ThunderBolt®Pro-XTM - Hex Head (Zinc Clear) sizes not included in ETA Assessment

Part No.	Size (mm)	Embed. Depth h_{nom} (mm)	Non cracked concrete						$C_{cr,N}$ (mm)	$S_{cr,N}$ (mm)	C_{min} (mm)	S_{min} (mm)
			20 MPa		32 MPa		40 MPa					
			Tension (kN)	Shear (kN)	Tension (kN)	Shear (kN)	Tension (kN)	Shear (kN)				
SXTM05050	5	25	0.8	1.4	1.0	1.5	1.2	1.7	60	60	30	30
SXTM06030	6	25	0.9	1.4	1.1	1.7	1.3	1.9	72	72	36	36
SXTM06050	6	30	1.2	2.5	1.3	3.0	1.4	3.2	72	72	36	36
SXTM08050	8	40	3.8	4.2	4.7	5.3	5.4	5.8	96	96	48	48
SXTM08060	8	40	3.8	4.2	4.7	5.3	5.4	5.8	96	96	48	48
SXTM10060	10	50	5.8	6.2	7.0	7.9	8.1	8.8	120	120	60	60
SXTM10075	10	50	5.8	6.2	7.0	7.9	8.1	8.8	120	120	60	60
SXTM12075	12	60	7.8	8.1	9.9	10.4	11.1	11.6	144	144	72	72
SXTM16100	16	80	13.9	13.4	17.5	16.5	19.6	18.9	192	192	96	96
SXTM16150	16	80	13.9	13.4	17.5	16.5	19.6	18.9	192	192	96	96



Note: The ThunderBolt® Pro-XTM non-approved anchor range may be used in applications that are considered NOT safety critical. For safety critical applications a design professional responsible for the application must review and approve the product as fit for purpose prior to use. Recommended loads (left) have an appropriate safety factor already incorporated in the loads based on the assessed mode of failure limits. Recommended loads (left) have been calculated based on single anchor installation at characteristic spacing and edge distance parameters. For specific design calculations please refer to ICCONS TDS 1028.1 for full details.

GALVANISED

INCLUDES AS 5216:2021 COMPLIANT RANGE

Flanged hex head with locking serrations designed to resist loosening and improve dynamic load performance

Asymmetric thread profile provides unparalleled bite in concrete

15 degree thread design provides fast installation and optimum performance

Stamped head for fast and accurate anchor identification

Diameter
ICCONS ID
Length

ThunderBolt® Pro-XTM (Galvanised)

GAL INTERNAL



Part No.	Head Style	Description (mm)	Drill Size (mm)	Embedment Depth h_{nom} (mm)	Drill Depth h_1 (mm)	Fixture Thickness (mm)	Clearance Hole (mm)	T_{inst} (Nm)	Impact Screw Gun T_{max} (Nm)	Installation Socket (mm)	ETA Assessment	Qty Inner	Qty Outer
Approved range - ETA-RNSS (multiple fixings) ETA-18/0644													
SXTM06060G-A	Hex	6 X 60	6	55	65	5	9	20	80	10	ETA-RNSS	100	600
SXTM06075G-A	Hex	6 X 75	6	55	65	20	9	20	80	10	ETA-RNSS	100	600
SXTM06100G-A	Hex	6 X 100	6	55	65	45	9	20	80	10	ETA-RNSS	100	600
SXTM06120G-A#	Hex	6 X 120	6	55	65	65	9	20	80	10	ETA-RNSS	100	600
AS 5216:2021 Compliant Range - ETA-Option 1 (single fixings) ETA-18/0643													
SXTM08075G-A	Hex	8 X 75	8	65	75	10	11	40	185	13	ETA 1	100	500
SXTM08100G-A	Hex	8 X 100	8	65	75	35	11	40	185	13	ETA1	100	400
SXTM08130G-A#	Hex	8 X 130	8	65	75	65	11	40	185	13	ETA1	100	400
SXTM10100G-A	Hex	10 X 100	10	75	85	25	13	60	350	17	ETA1	50	250
SXTM10120G-A	Hex	10 X 120	10	75	85	45	13	60	350	17	ETA1	50	250
SXTM10140G-A	Hex	10 X 140	10	75	85	65	13	60	350	17	ETA1	50	250
SXTM10150G-A	Hex	10 X 150	10	75	85	75	13	60	350	17	ETA1	50	250
SXTM12100G-A	Hex	12 X 100	12	95	105	5	15	80	350	19	ETA1	50	150
SXTM12120G-A	Hex	12 X 120	12	95	105	25	15	80	350	19	ETA1	25	125
SXTM12150G-A	Hex	12 X 150	12	95	105	55	15	80	350	19	ETA1	25	75
Range not included in ETA Assessment													
SXTM05050G	Hex	5 X 50	5	25	35	25	7	15	80	8	-	100	1600
SXTM06030G	Hex	6 X 30	6	25	35	5	9	20	80	10	-	100	1600
SXTM06050G	Hex	6 X 50	6	30	40	20	9	20	80	10	-	100	1200
SXTM08050G	Hex	8 X 50	8	40	50	10	11	40	185	13	-	100	600
SXTM08060G	Hex	8 X 60	8	40	50	20	11	40	185	13	-	100	600
SXTM10060G	Hex	10 X 60	10	50	60	10	13	60	350	17	-	50	250
SXTM10075G	Hex	10 X 75	10	50	60	25	13	60	350	17	-	50	250
SXTM12075G	Hex	12 X 75	12	60	70	15	15	80	350	19	-	50	150
SXTM16100G	Hex	16 X 100	16	80	90	20	19	100	350	24	-	15	60
SXTM16150G	Hex	16 X 150	16	80	90	70	19	100	350	24	-	15	60

* Max. power output of impact screw gun | ETA-RNSS = ETA Redundant Non Structural System | ETA 1 = ETA Option 1 = AS 5216 Compliant | # NZ Sizes only



Chamfered tip centres anchor and aids for easy installation

Unique two step heat treatment process

1st Step Case hardening to provide the shank of the screw with adequate strength, good ductility and hydrogen embrittlement resistant characteristics.

2nd Step Selective through hardening to provide the drill point and lead threads with good drilling and tapping performance.

Dual hardness technology for use in hard concrete

Lower-hardness (below 34 HRC) load bearing section

Higher hardness 55 HRC (min) drill point and lead threads for reliable under-cutting of the base material



National Code Compliant



European Technical Assessment



Cracked Concrete Approved



Fire Rated Fasteners



Free Download iccons.com.au



Design Loads - approved ThunderBolt®Pro-XTM - Hex Head (Galvanised)

Part No.	Size (mm)	Embed. Depth h_{nom} (mm)	Non cracked concrete						Cracked concrete						$C_{cr,N}$ (mm)	$S_{cr,N}$ (mm)	C_{min} (mm)	S_{min} (mm)
			20 MPa		32 MPa		40 MPa		20 MPa		32 MPa		40 MPa					
			Tension (kN)	Shear (kN)	Tension (kN)	Shear (kN)	Tension (kN)	Shear (kN)	Tension (kN)	Shear (kN)	Tension (kN)	Shear (kN)	Tension (kN)	Shear (kN)				
Design Loads - ETA-RNSS (multiple fixings) ETA-18/0644 (Part 6)																		
SXTM06060G-A	6	55	3.3	5.3	4.2	5.3	4.7	5.3	3.3	5.3	4.2	5.3	4.7	5.3	64	128	40	40
SXTM06075G-A	6	55	3.3	5.3	4.2	5.3	4.7	5.3	3.3	5.3	4.2	5.3	4.7	5.3	64	128	40	40
SXTM06100G-A	6	55	3.3	5.3	4.2	5.3	4.7	5.3	3.3	5.3	4.2	5.3	4.7	5.3	64	128	40	40
SXTM06120G-A#	6	55	3.3	5.3	4.2	5.3	4.7	5.3	3.3	5.3	4.2	5.3	4.7	5.3	64	128	40	40
Design loads - ETA Option 1 (single fixings) ETA-18/0643 - AS 5216:2021 Compliant Range																		
SXTM08075G-A	8	65	4.3	11.3	5.4	11.3	6.0	11.3	2.1	8.3	2.7	10.5	3.0	11.3	76	152	50	50
SXTM08100G-A	8	65	4.3	11.3	5.4	11.3	6.0	11.3	2.1	8.3	2.7	10.5	3.0	11.3	76	152	50	50
SXTM08130G-A#	8	65	4.3	11.3	5.4	11.3	6.0	11.3	2.1	8.3	2.7	10.5	3.0	11.3	76	152	50	50
SXTM10100G-A	10	75	10.7	14.5	13.4	17.9	15.0	17.9	6.7	10.2	8.4	12.9	9.4	14.4	88	175	60	60
SXTM10120G-A	10	75	10.7	14.5	13.4	17.9	15.0	17.9	6.7	10.2	8.4	12.9	9.4	14.4	88	175	60	60
SXTM10140G-A	10	75	10.7	14.5	13.4	17.9	15.0	17.9	6.7	10.2	8.4	12.9	9.4	14.4	88	175	60	60
SXTM10150G-A	10	75	10.7	14.5	13.4	17.9	15.0	17.9	6.7	10.2	8.4	12.9	9.4	14.4	88	175	60	60
SXTM12100G-A	12	95	13.9	26.0	17.5	26.0	19.6	26.0	6.7	26.0	8.4	26.0	9.4	26.0	114	226	70	70
SXTM12120G-A	12	95	13.9	26.0	17.5	26.0	19.6	26.0	6.7	26.0	8.4	26.0	9.4	26.0	114	226	70	70
SXTM12150G-A	12	95	13.9	26.0	17.5	26.0	19.6	26.0	6.7	26.0	8.4	26.0	9.4	26.0	114	226	70	70

Note: The ThunderBolt®Pro-XTM anchor may be used in cracked or non-cracked concrete applications subject to static or quasi-static loading in reinforced or unreinforced normal weight concrete of strength classes C20/25 - C50/60. • Performance data in the above table has been calculated using the relevant published ETA documents and based on single anchor installation at characteristic spacing and edge distance parameters. • Compliance is in accordance with AS 5216:2021, for specific design calculations refer to ICCONS Designfix software for further details.
• $C_{cr,N}$ = Characteristic edge distance, $S_{cr,N}$ = Characteristic spacing, C_{min} = Minimum edge distance, S_{min} = Minimum spacing. #NZ sizes only.

Recommended Loads - ThunderBolt®Pro-XTM - Hex Head (Galvanised) sizes not included in ETA Assessment

Part No.	Size (mm)	Embed. Depth h_{nom} (mm)	Non cracked concrete						$C_{cr,N}$ (mm)	$S_{cr,N}$ (mm)	C_{min} (mm)	S_{min} (mm)
			20 MPa		32 MPa		40 MPa					
			Tension (kN)	Shear (kN)	Tension (kN)	Shear (kN)	Tension (kN)	Shear (kN)				
SXTM05050G	5	25	0.8	1.4	1.0	1.5	1.2	1.7	60	60	30	30
SXTM06030G	6	25	0.9	1.4	1.1	1.7	1.3	1.9	72	72	36	36
SXTM06050G	6	30	1.2	2.5	1.3	3.0	1.4	3.2	72	72	36	36
SXTM08050G	8	40	3.8	4.2	4.7	5.3	5.4	5.8	96	96	48	48
SXTM08060G	8	40	3.8	4.2	4.7	5.3	5.4	5.8	96	96	48	48
SXTM10060G	10	50	5.8	6.2	7.0	7.9	8.1	8.8	120	120	60	60
SXTM10075G	10	50	5.8	6.2	7.0	7.9	8.1	8.8	120	120	60	60
SXTM12075G	12	60	7.8	8.1	9.9	10.4	11.1	11.6	144	144	72	72
SXTM16100G	16	80	13.9	13.4	17.5	16.5	19.6	18.9	192	192	96	96
SXTM16150G	16	80	13.9	13.4	17.5	16.5	19.6	18.9	192	192	96	96



Note: The ThunderBolt®Pro-XTM non-approved anchor range may be used in applications that are considered NOT safety critical. For safety critical applications a design professional responsible for the application must review and approve the product as fit for purpose prior to use. Recommended loads (left) have an appropriate safety factor already incorporated in the loads based on the assessed mode of failure limits. Recommended loads (left) have been calculated based on single anchor installation at characteristic spacing and edge distance parameters. For specific design calculations please refer to ICCONS TDS 1028.1 for full details.

STAINLESS STEEL

INCLUDES AS 5216:2021

UNIQUE BI-METAL WELDING TECHNOLOGY

Fastening thread 316 Series Austenitic Stainless Steel providing long term performance.

Carbon alloy tapping thread Unique hardening process provides good tapping performance in concrete

Asymmetric thread profile provides unparalleled bite in concrete

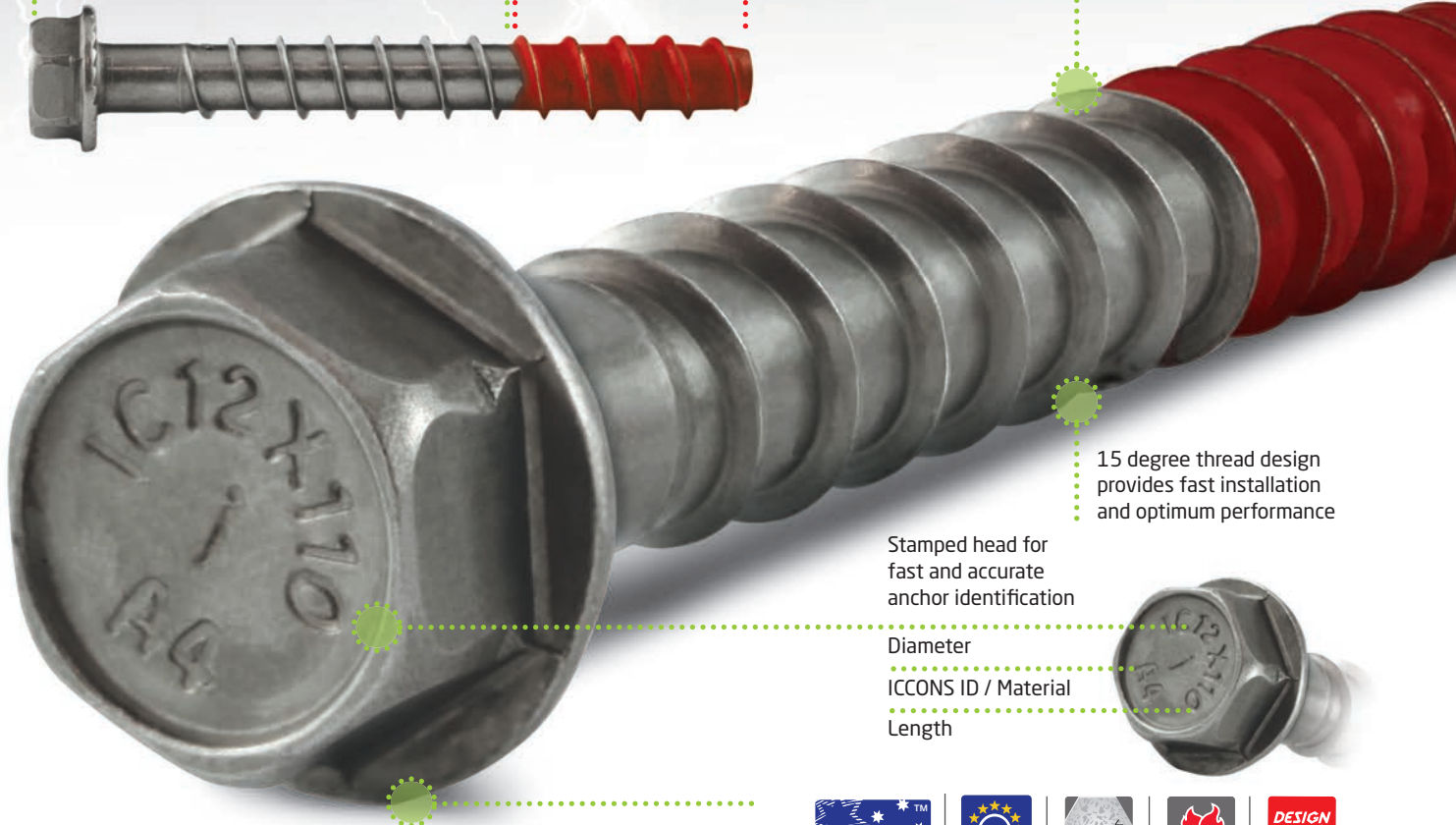

15 degree thread design provides fast installation and optimum performance

Stamped head for fast and accurate anchor identification

Diameter
ICCONS ID / Material
Length

Flanged hex head with locking serrations designed to resist loosening and improve dynamic load performance

ThunderBolt® Pro-XTM (Stainless Steel)



National Code Compliant



European Technical Assessment



Cracked Concrete Approved



Fire Rated Fasteners



Free Download
iccons.com.au

316 SS EXTERNAL



Part No.	Head Style	Description (mm)	Drill Size (mm)	Embedment Depth h_{nom} (mm)	Drill Depth h_1 (mm)	Fixture Thickness (mm)	Clearance Hole (mm)	Impact Screw Gun T_{max} (Nm)	CSK Head Diameter (mm)	Installation Socket/Torx	ETA Assessment	Qty Inner	Qty Outer
Approved range - ETA-RNSS (multiple fixings) ETA-18/0644 (Part 6)													
SXTM06075SS-A	Hex	6 x 75	6	70	80	5	9	80-120		10	ETA-RNSS	100	400
SXTM08070SS-A	Hex	8 x 70	8	52	62	18	11	120		13	ETA-RNSS	80	320
SXTMCS06080SS-A	CSK	6 x 80	6	70	80	10	9	80-120	15.6	T-40	ETA-RNSS	100	400
AS 5216:2021 Compliant Range - Option 1 (single fixings) ETA-18/0643													
SXTM08090SS-A	Hex	8 x 90	8	85	95	5	11	120		13	ETA 1	80	320
SXTM10120SS-A	Hex	10 x 120	10	100	110	20	13	185		17	ETA 1	35	140
SXTM12125SS-A	Hex	12 x 125	12	120	130	5	15	185		19	ETA 1	25	100
SXTMCS08095SS-A	CSK	8 x 95	8	85	95	10	11	120	18.0	T-45	ETA 1	80	320
Range not included in ETA Assessment													
SXTM06060SS	Hex	6 x 60	6	55	65	5	9	80-120		10	-	100	400
SXTM10090SS	Hex	10 x 90	10	75	85	15	13	185		17	-	45	180
SXTM10100SS	Hex	10 x 100	10	75	85	25	13	185		17	-	45	180
SXTM12110SS	Hex	12 x 110	12	95	105	15	15	185		19	-	30	120

* Max. power output of impact screw gun | ETA-RNSS = ETA Redundant Non Structural System | ETA 1 = ETA Option 1 = AS 5216 Compliant



COMPLIANT RANGE

Stamped CSK head for fast and accurate anchor identification

Chamfered tip centres anchor and aids for easy installation

Dual hardness technology for use in hard concrete

Carbon alloy tapping thread Unique hardening process provides good tapping performance in concrete

UNIQUE BI-METAL WELDING TECHNOLOGY

Fastening thread 316 Series Austenitic Stainless Steel providing long term performance.



Design Loads - Approved ThunderBolt®Pro-XTM - Hex and CSK Head (Stainless Steel)

Part No.	Size (mm)	Embed. Depth h_{nom} (mm)	Non cracked concrete						Cracked concrete						$C_{cr,N}$ (mm)	$S_{cr,N}$ (mm)	C_{min} (mm)	S_{min} (mm)
			20 MPa		32 MPa		40 MPa		20 MPa		32 MPa		40 MPa					
			Tension (kN)	Shear (kN)	Tension (kN)	Shear (kN)	Tension (kN)	Shear (kN)	Tension (kN)	Shear (kN)	Tension (kN)	Shear (kN)	Tension (kN)	Shear (kN)				
Design Loads - ETA-RNSS (multiple fixings) ETA-18/0644 (Part 6)																		
SXTM06075SS-A	6	70	3.3	6.8	4.2	7.2	4.7	7.2	3.3	6.8	4.2	7.2	4.7	7.2	65	130	40	40
SXTMCS06080SS-A	6	70	2.3	4.9	2.9	4.9	3.3	4.9	2.3	4.9	2.9	4.9	3.3	4.9	65	130	40	40
SXTM08070SS-A	8	52	1.3	2.5	1.6	3.2	1.8	3.6	1.3	2.5	1.6	3.2	1.8	3.6	65	130	50	50
Design loads - ETA Option 1 (single fixings) ETA-18/0643 - AS 5216:2021 Compliant Range																		
SXTM08090SS-A	8	85	4.3	12.6	5.4	13.2	6.1	13.2	2.1	9.0	2.7	11.4	3.0	12.7	78	156	50	50
SXTMCS08095SS-A	8	85	2.6	9.0	3.3	9.0	3.7	9.0	2.1	9.0	2.7	9.0	3.0	9.0	78	156	50	50
SXTM10120SS-A	10	100	10.7	15.1	13.5	19.2	15.1	21.4	4.7	10.8	5.9	13.7	6.6	15.3	89	177	60	60
SXTM12125SS-A	12	120	13.9	31.2	17.5	31.2	19.6	31.2	6.7	31.2	8.4	31.2	9.5	31.2	114	227	70	70

Note: The ThunderBolt®Pro-XTM anchor may be used in cracked or non-cracked concrete applications subject to static or quasi-static loading in reinforced or unreinforced normal weight concrete of strength classes C20/25 - C50/60. • Performance data in the above table has been calculated using the relevant published ETA documents and based on single anchor installation at characteristic spacing and edge distance parameters. • Compliance is in accordance with AS 5216:2021, for specific design calculations refer to ICCONS Designfix software for further details. • $C_{cr,N}$ = Characteristic edge distance, $S_{cr,N}$ = Characteristic spacing, C_{min} = Minimum edge distance, S_{min} = Minimum spacing

Recommended Loads - ThunderBolt®Pro-XTM - Hex Head (Stainless Steel) sizes not included in ETA Assessment

Part No.	Size (mm)	Embed. Depth h_{nom} (mm)	Non cracked concrete						$C_{cr,N}$ (mm)	$S_{cr,N}$ (mm)	C_{min} (mm)	S_{min} (mm)
			20 MPa		32 MPa		40 MPa					
			Tension (kN)	Shear (kN)	Tension (kN)	Shear (kN)	Tension (kN)	Shear (kN)				
SXTM06060SS	6	55	1.3	2.5	1.6	3.2	1.8	3.6	72	72	36	36
SXTM10090SS	10	75	4.3	12.6	5.4	13.2	6.1	13.2	120	120	60	60
SXTM10100SS	10	75	4.3	12.6	5.4	13.2	6.1	13.2	120	120	60	60
SXTM12110SS	12	95	10.7	15.1	13.5	19.2	15.1	21.4	144	144	72	72



Note: The ThunderBolt®Pro-XTM non-approved anchor range may be used in applications that are considered NOT safety critical. For safety critical applications a design professional responsible for the application must review and approve the product as fit for purpose prior to use. Recommended loads (left) have an appropriate safety factor already incorporated in the loads based on the assessed mode of failure limits. Recommended loads (left) have been calculated based on single anchor installation at characteristic spacing and edge distance parameters. For specific design calculations please refer to ICCONS TDS 1028.1 for full details.

THUNDERBOLT® PRO-X™

Includes AS 5216:2021 Compliant Range

Hex Head Installation

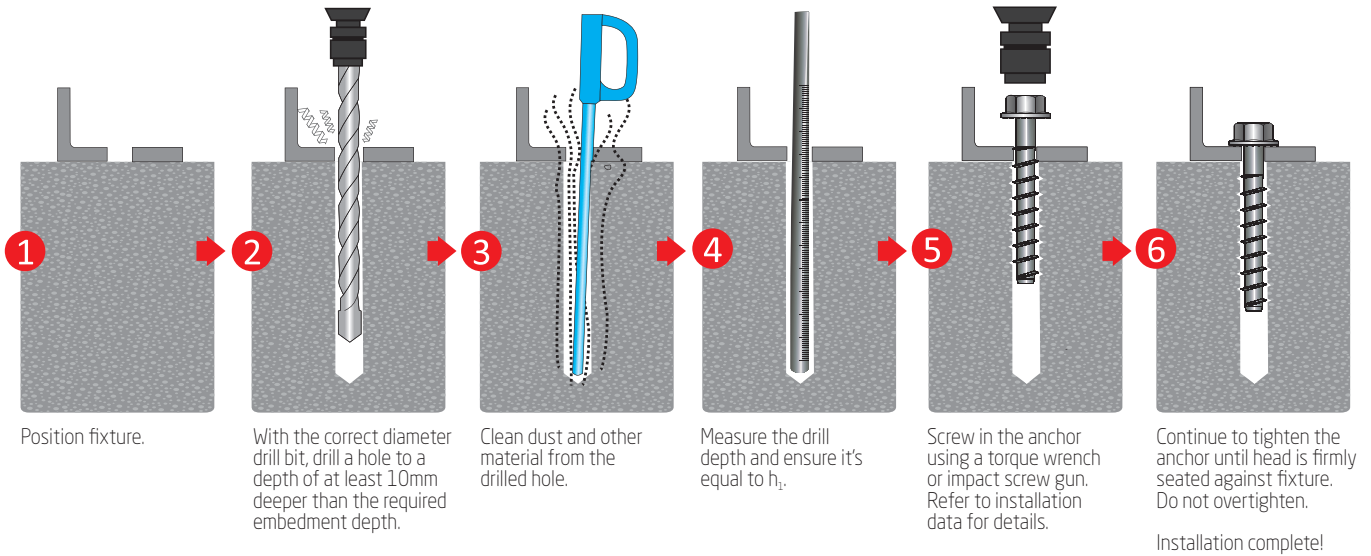

Countersunk Head Installation

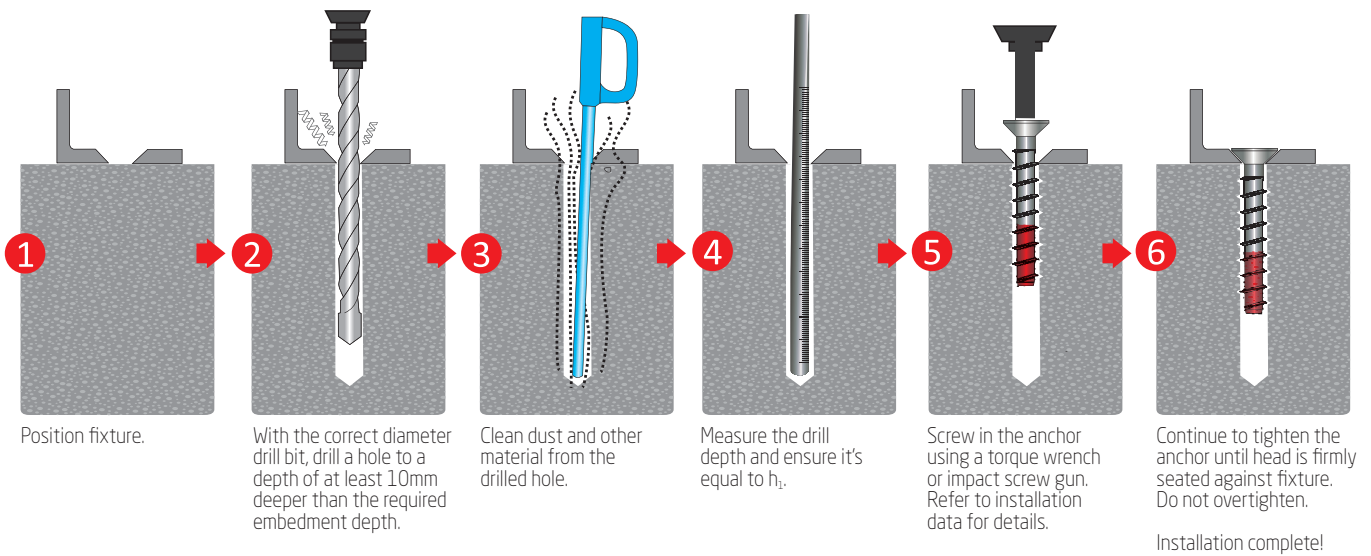

Installation data

Anchor Size	mm	6		8		10		12	
		ETA Assessment (RNSS)	ETA Assessment (RNSS)	ETA Assessment Option 1	ETA Assessment Option 1	ETA Assessment Option 1	ETA Assessment Option 1		
Drill Dia.	(mm)	6	8		10	12			
Embed. Depth h_{nom}	(mm)	70	52	85	100	120			
Drill Depth h_1	(mm)	80	62	95	110	130			
Minimum Concrete Thickness - Zinc/Galv.	(mm)	100	110	110	130	160			
Minimum Concrete Thickness - 316 S/S	(mm)	110	125	125	140	170			
Clearance hole	(mm)	9	11		13	15			
Impact Screw Gun T_{max}^*	(Nm)	80-120		120	185	185			
Installation - Socket/Torx	(mm)	10mm / T-40		13mm / T-45	17	19			

*Maximum torque capacity of Impact Screw Gun for use during installation

Base Materials



Cracked Concrete



Hollow Block



Non-Cracked Concrete



Solid Sand-lime Brick



Hollow Concrete Block



Hollow Sand-lime Brick



ThunderBolt®Pro-XTM Applications

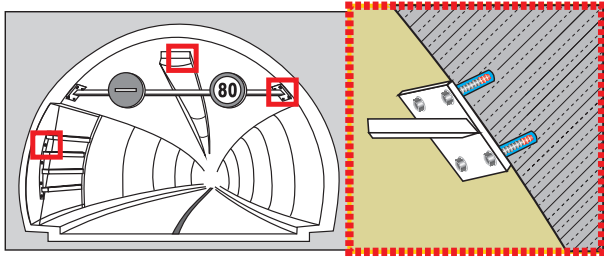

Tunnel fitout

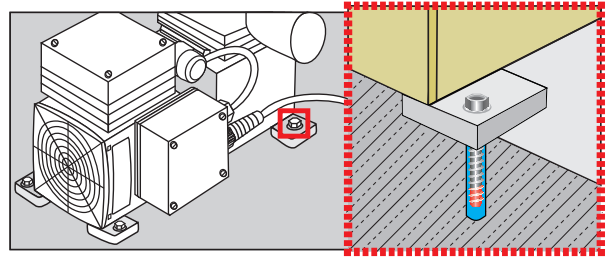

Machinery and equipment fixing

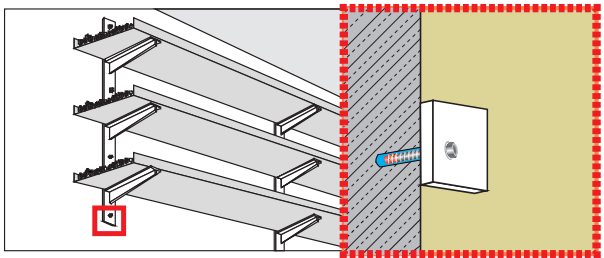

Racking

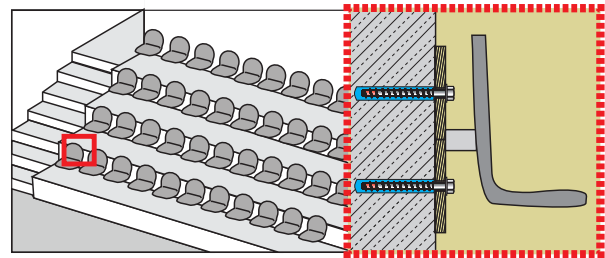

Stadium seating

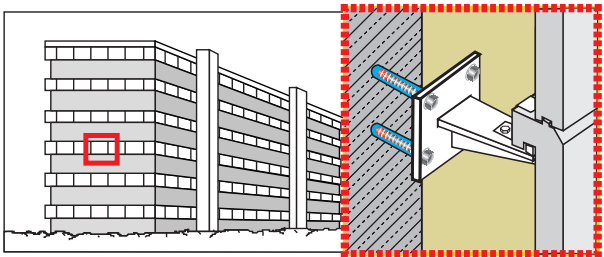

Facade structures

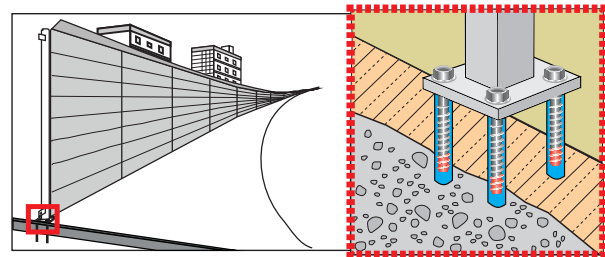

Acoustic barriers

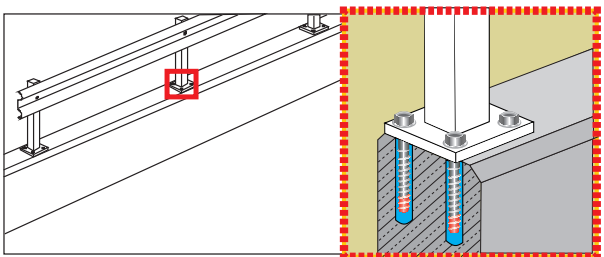

Guardrails

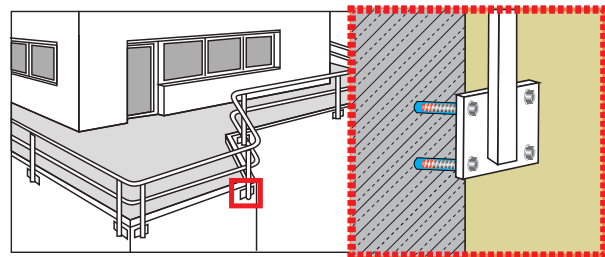

Railings

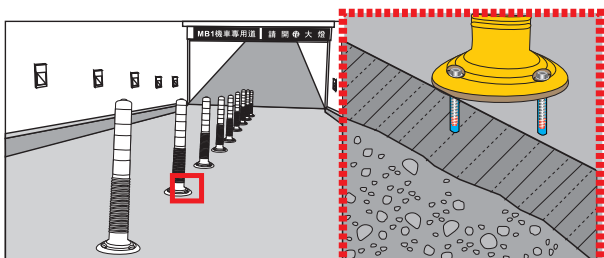

Bollards

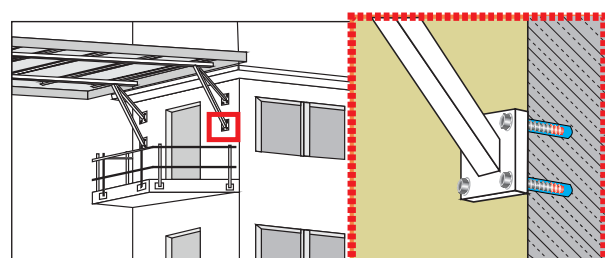

Supporting systems



Includes AS 5216:2021 Compliant Range

TDS | 1027.3

Flanged hex head with locking serrations designed to resist loosening and improve dynamic load performance

Stamped head for fast and accurate anchor identification

Asymmetric thread profile provides unparalleled bite in concrete

15 degree thread design provides fast installation and optimum performance

Chamfered tip centres anchor and aids for easy installation

Dual hardness technology for use in hard concrete

ICCONS[®] PTY LTD

VICTORIA - HEAD OFFICE
383 Frankston Dandenong Rd,
Dandenong South,
Vic, 3175
P: **03 9706 4344**

NSW Branch
Unit A, 17 Seddon Street,
Bankstown,
New South Wales, 2200
P: **02 9791 6869**

QLD Branch
42-44 Nealdon Dr
Meadowbrook,
Queensland, 4131
P: **07 3200 6455**

FNQ Branch
41 Corporate Crescent
Garbutt,
Queensland, 4814
P: **07 2111 3453**

S.A Branch
29-31 Weaver Street,
Edwardstown,
South Australia 5039
P: **08 8234 5535**

W.A. Branch
90 Christable Way,
Landsdale,
Western Australia, 6065
P: **08 6305 0008**

NORTHERN TERRITORY
Unit 1, 14 Menmuir Street,
Winnellie,
Northern Territory 0820
P: **08 8947 2758**

NEW ZEALAND

Sesto Fasteners
5E Piermark Road,
Albany, Auckland,
New Zealand 0630
P: **+64 9415 8564**
E: sestofasteners@gmail.com

THAILAND

ICCONS (Thailand) Co. Ltd.
55 Phetkasem 62/3, Bangkokhae,
Bangkok 0160
P: **+ 66 2 801 0764**
F: **+ 66 2 801 0764**
M: **+ 66 8 1 710 8745**
E: icconsthailand@hotmail.com